

YXLON CT Compact

Fan-beam computed tomography (CT) inspection system
for high-density medium and large-sized parts

Discover the difference in efficiency

New YXLON line detector
technology for outstanding
image quality



YXLON
Technology with Passion



Explore the art of detection

As a world leader in non-destructive X-ray testing YXLON has mastered the art of detection. Based on our long experience in designing tailor-made X-ray and CT solutions, we help our customers achieve excellent results during their scientific research and development projects as well as production inspection procedures. Making the invisible visible – that's what we call the art of detection.

No matter what industry you're in, we provide you with reliable 3D components analyses and accurate dimensional measurements. Are you doing research in the field of geology, archeology or material science and engineering? Do you need to inspect cultural artifacts? YXLON's computed tomography (CT) excellence also supports you in your scientific and art-related testing.

Because YXLON CT solutions are tried and tested premium systems, they blend smoothly into your processes, guaranteeing a fast workflow and high uptime. Our CT product range equips you with relevant information regarding the interior and exterior structures of your items in one data set. This way, you reduce your inspection time, allowing you to concentrate on your core business.

Additionally, the worldwide YXLON service network is an important factor to be taken into account when evaluating the YXLON CT price-performance ratio – one that appeals to quality managers, operations personnel, and purchasers alike.

Where do you use YXLON CT systems?

- Analysis of porosities and inclusions
- Dimensional measurement
- Analysis of composite materials (carbon / glass fiber reinforced plastic)
- Assembly or structural analysis
- Wall thickness measurements
- Nominal / actual comparison
- Examination of historical art and archeological objects
- Investigation of geological samples

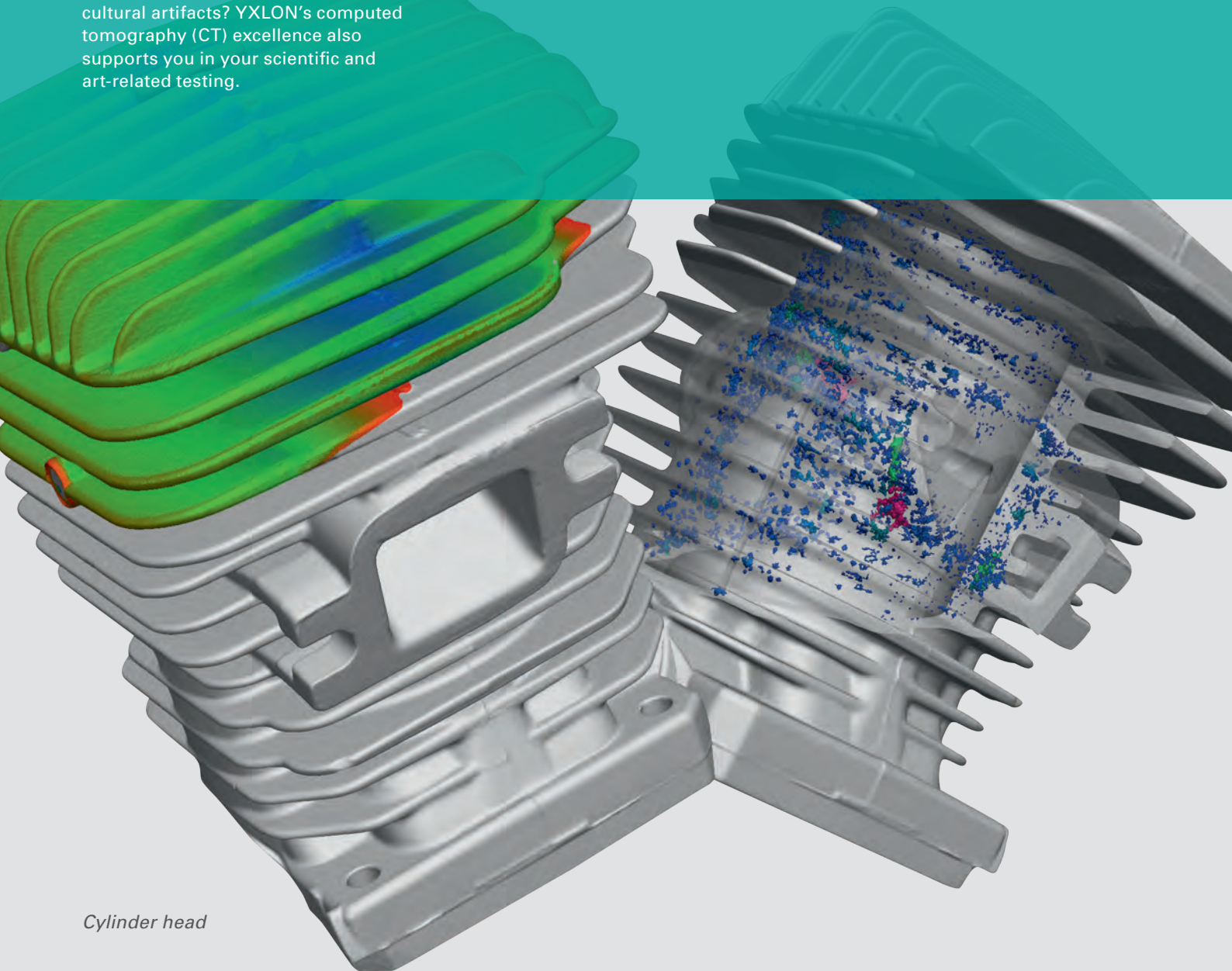

Cylinder head



Perform 3D inspections efficiently

Do you need to inspect large parts with a high density? Are you looking for an efficient entry point into the benefits of industrial CT? Experience the easy-to-use CT Compact which saves time thanks to the outstanding function of defining single CT slices.

Benefit from premium 3D quality control and low testing costs per unit item. Automatic image enhancement via dedicated software algorithms significantly contributes to the premium image quality of CT Compact.

In one test run you can create CT slices with different parameters for different areas of the test parts. This way, you speed up the testing process while maintaining image quality. Inspection time is also minimized via our multiple parts testing feature – conveniently covering more than one item per test run.

YXLON has developed a linear detector array (LDA) that further guarantees homogenous image quality and provides an unprecedented signal-to-noise ratio. Our detector calibration process helps ensure consistent image quality.

YXLON CT Compact key benefits

- Intelligent image enhancement for improved image quality
- Programmable parameters for different inspection areas to speed up processes
- Multiple parts tested in one inspection run to boost workflow
- Special software features like beam hardening correction and horizontal field-of-view (FOV) extension



Detect what matters

Easy-to-use CT Compact provides you with high-resolution 3D images – the perfect foundation for reliable inspections in your facility.

Geological sample

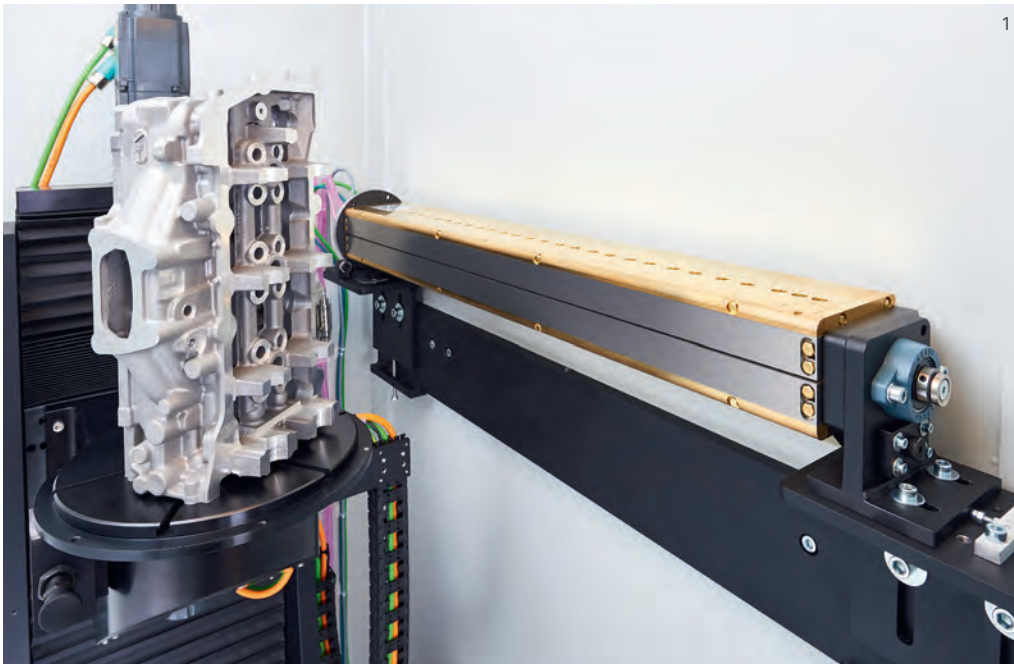

1 View inside the cabin with the new YXLON line detector technology

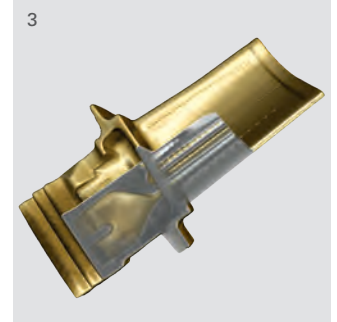
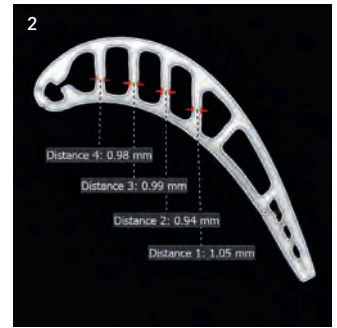

2 Dimensional measurement example of a turbine blade
3 Volume of a turbine blade

Use a workhorse with extra power

The system is equipped with a high-power X-ray tube and a line detector array developed by YXLON. CT Compact generates high energy to effectively penetrate iron components up to 65 mm (ca. 2.6") thick and aluminum parts up to 250 mm (ca. 9.9"). In only 30 seconds you can analyze the 3D image or the stacked 3D model.

The mechanical capacity and performance is complemented by a number of process-enhancing software tools integrated into every CT Compact set-up.

Automated center determination and beam hardening corrections eliminate the need for time-consuming manual interaction.

With the CT Compact YXLON provides you with reasonably priced access to the advantages of industrial computed tomography. The system is designed for years of peak-performance inspections. You can count on rock-solid hardware and software components that reliably allow you to carry out production monitoring, quality control and prototype construction.

Which items and materials are especially suitable for YXLON CT Compact?

- Heavy metal castings
- Aluminum and steel components
- Cylinder heads, engine blocks and transmission housings
- Dense historical art and archeological objects
- Large geological samples



YXLON Life Cycle Service – more than the best image

YXLON Life Cycle Service

- **Y.ServicePass** – the most important services tailored to your system and your needs
- **Y.SmartPass** – for customers who need instantaneous spare parts availability
- **Y.LifeCyclePass** – the all-inclusive package covering all costs throughout the entire system lifetime
- **Y.WarrantyPass** – predictable costs by extending the warranty for one or two years
- **Y.SmartSpares** – the best compatibility and added functionality using original YXLON spare parts
- **Y.Exchange** – direct replacement of defective or worn-out components to minimize system downtimes
- **Y.Updates** – up-to-date system technology and prolonged lifetime
- **Y.Academy** – professional training teaches your operators how to get the most out of the system

What are your specific service requirements? We offer a wide range of service modules and packages tailored to your needs.

Our highly qualified global service team is committed to providing excellent service to our customers worldwide. With eight global service centers and specialized staff at over 50 service partners, we can ensure a rapid response time wherever and whenever you need it.

Your benefits include:

- High system availability
- Low operating costs
- Superior inspection results
- Guaranteed operational safety
- Prolonged system lifetime

We align our organization and all service activities to comply with your requirements. With our innovative, modular service solutions you can count on true added value throughout the entire life cycle of your system.

We support you in keeping your inspection costs to a minimum. At the same time, your systems operate safely at peak performance while providing optimum inspection results throughout their entire lifetime.

Check out these facts and figures

System Principles		YXLON CT Compact XL-Mag		CT Parameters	
Inspection Mode		Fan-beam CT		Focus Detector Distance (FDD) ³⁾	1,375 mm
Manipulation		3 axes		Magnification ³⁾	1.37 / 2.0 / 2.6
X-ray Components				Voxel size ⁴⁾	down to 70 μm
X-ray Tube		Y.TU450-D11		Maximum Field of View (FOV)	
Maximum energy		450 kV		Standard mode ($\varnothing \times h$)	370 mm x 750 mm @ Mag 1.37 250 mm x 750 mm @ Mag 2.0 195 mm x 750 mm @ Mag 2.6
Maximum power ¹⁾		0.7 kW / 1.5 kW		Extended mode ($\varnothing \times h$) ⁵⁾	660 mm x 750 mm @ Mag 1.37 460 mm x 750 mm @ Mag 2.0 360 mm x 750 mm @ Mag 2.6
Focal spot ¹⁾		0.4 mm / 1.0 mm		Minimum scan time	< 15 sec. per slice
Detector		YXLON CTScan 3-0780		Minimum reconstruction time	< 15 sec. per slice (computed in parallel to scan of next slice)
Active length		765 mm (780 mm)			
Pixel pitch		254 μm			
Temperature stabilization		yes			
Inspection Item				Cabinet	
Maximum part size ($\varnothing \times h$) ²⁾		660 mm x 820 mm		Cabinet size (w x h x d), approx.	2,460 mm x 2,770 mm x 1,860 mm
Turntable diameter		300 mm (600 mm optional)		Cabinet weight, approx.	13,000 kg
Maximum table load		50 kg			

¹⁾ Selectable by software. Smaller focal spot will result in lower maximum power.

³⁾ Deviations are possible in the known tolerances.

⁴⁾ Determined by geometry and reconstruction parameters without undersampling.

⁵⁾ Utilizing horizontal field-of-view extension.

²⁾ Taller parts may be accommodated by rescanning in different orientation.

Values are for standard system design and are approximate. See technical description for details. Other configurations on request.

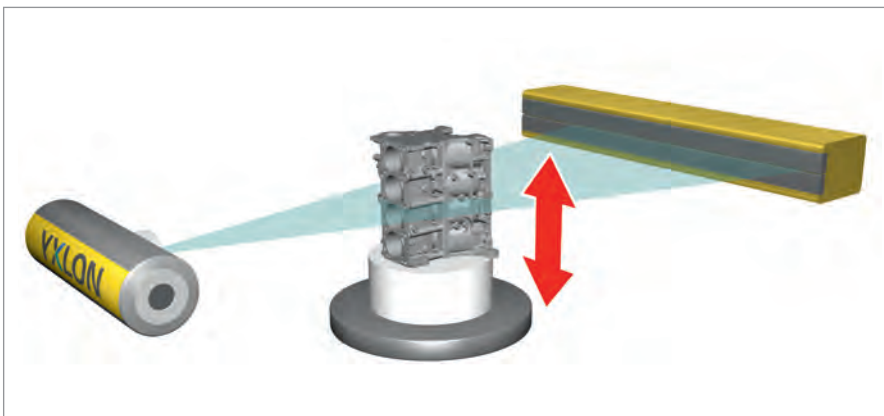
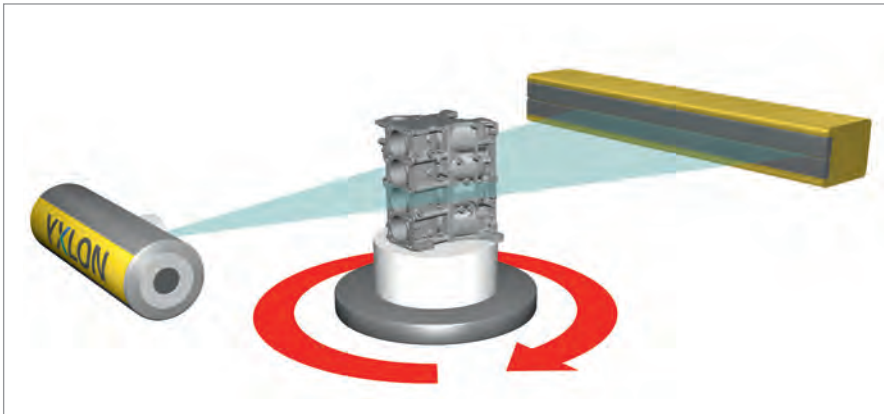

Principle of fan-beam CT: Rotation of part is followed by a vertical movement. This sequence is repeated until the desired area is scanned.

**Find the system
that suits you best**



	YXLON CT Compact	YXLON FF85 CT
Inspection mode	Fan beam CT	Cone beam CT
Part size	+	++
Material desity	+++	++
Part weight	+	++
Detail visibility	+	++
2D (digital radioscopy)	N/A	✓
Helical scan	N/A	✓

Would you like to learn more about our systems? Interested in a test inspection? Please contact us by phone or e-mail. We look forward to hearing from you.

YXLON

Technology with Passion

GERMANY – HEADQUARTERS

YXLON International GmbH
Essener Bogen 15
22419 Hamburg
Germany
T: +49 40 527 29-0

www.yxlon.com

CHINA

**YXLON (Beijing)
X-ray Equipment Trading Co., Ltd.**
Middlegate, First Floor, Building 2,
103 Beiqing Road,
Haidian Dist. Beijing 100004,
China
T: +86 10 8857 9581
F: +86 10 8857 9580

USA

**YXLON Sales & Service Location
COMET Technologies USA Inc.**
5675 Hudson Industrial Parkway
Hudson, OH 44236
USA
T: +1 234-284-7849

JAPAN

YXLON International KK
New Stage Yokohama Bldg.,
1st Floor
1-1-32 Shinurashima-cho
Kanagawa-ku
Yokohama, 221-0031
Japan
T: +81 45 450 1730